

# Dividing Machine

SDM

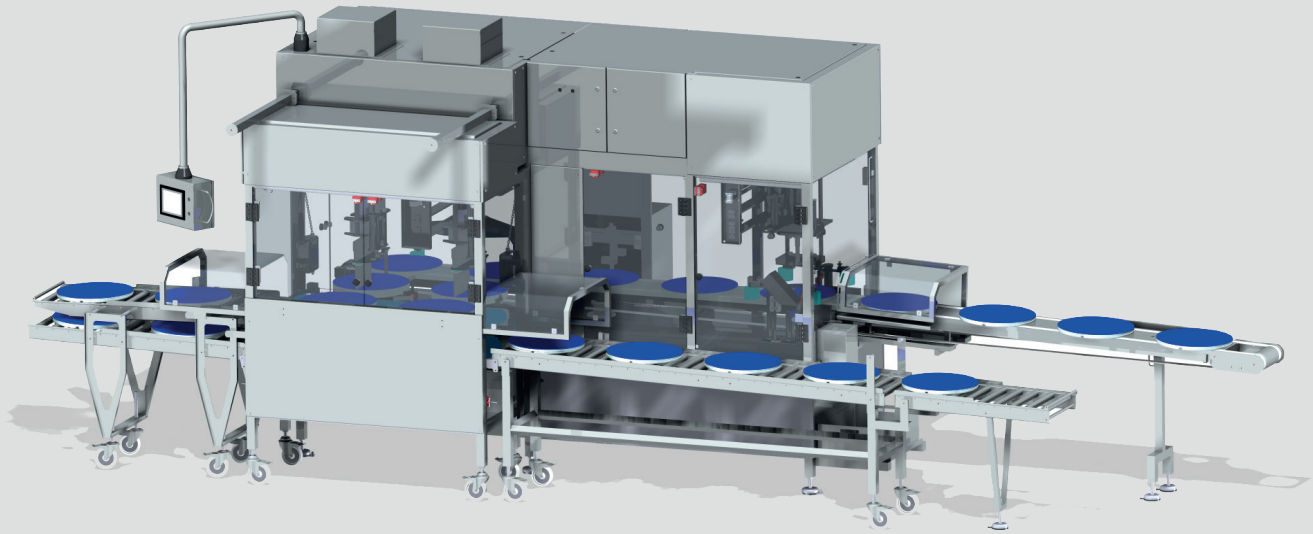

Member of iXAPACK GLOBAL

## Ultrasonic cutting

The SELVEX Dividing Machine with follower tray is an equipment developed for the ultrasonic cutting of round cheese in angular parts. Equipped with 1 or 2 heads of cutting, the dividing machine can achieve up to 80 cycles per minute (according to the product).

### Several types of cutting are taking care by the dividing machine:

- Cutting with fixed weight: determined by weighing and/or modelling post (3D vision or X-ray). The cutting with fixed weight respects European norm TU1/TU2.
- Cutting with variable weight: which respects a defined corner cutting.
- Cutting with a calculated variable weight: definition of a weight with distribution of the possible fall on all portions, respecting European norm TU1/TU2

### The ultrasounds technology:

The ultrasonic cutting is done thanks to a specific blade called "sonotrode" that vibrates at a frequency situated between 20 and 30 kHz. This vibratory frequency is achieved with an ultrasound generator. Consequently, the sonotrode acts as a knife driven by an alternative movement reproduced 20 000 times a second. This results in a substantial decrease of the cutting effort and a very weak clogging of the blade. Therefore, this technology is especially suitable for the cutting of fragile products.



## Benefits and advantages

- Cutting of multitude formats without change of tools.
- Dividing machine equipped with follower tray (trays where products are cut) composed of a special coating which supports the repeated blows of blades without corrupting them.
- Display of statistics, of instructions and faults, configuration and memorizing of formats via a 19" color touch screen.
- High pressure cleaning possible

## Les options

- Centring of the product on the tray
- Core cutting
- Weighing
- Modelling by 3D vision
- Modelling by X-Ray
- Portions destacking
- Trays returning (manual or automatic)
- ...

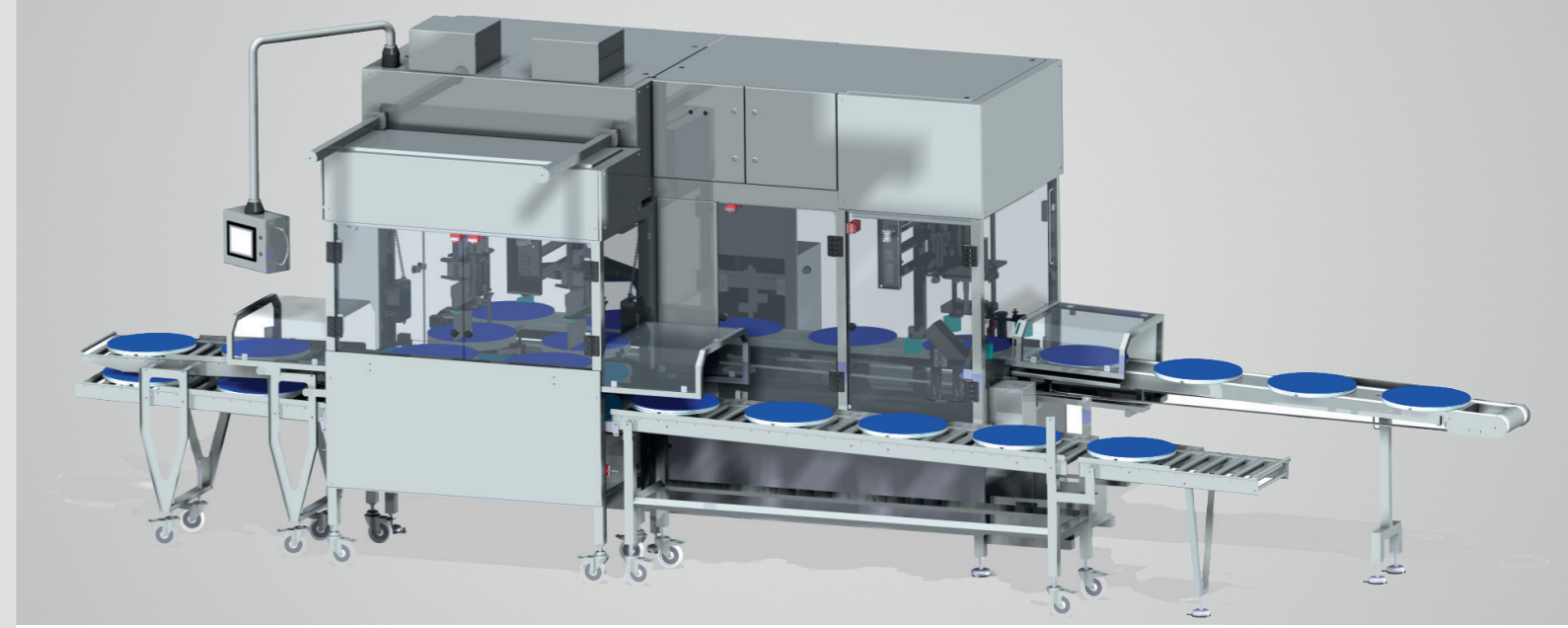

Cadence	from 60 to 80 cycles / minutes (according to the product)
Diameter of product	from 100 mm to 440 mm
Height of product	maxi 135 mm

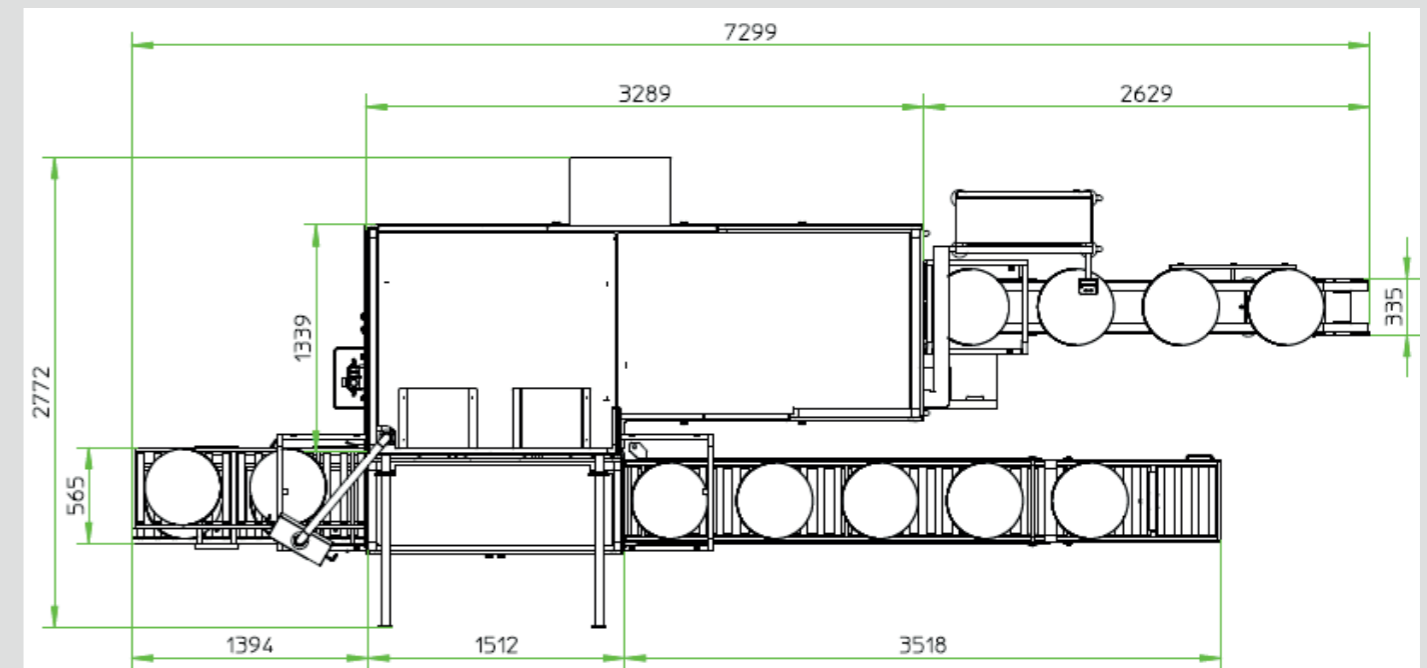
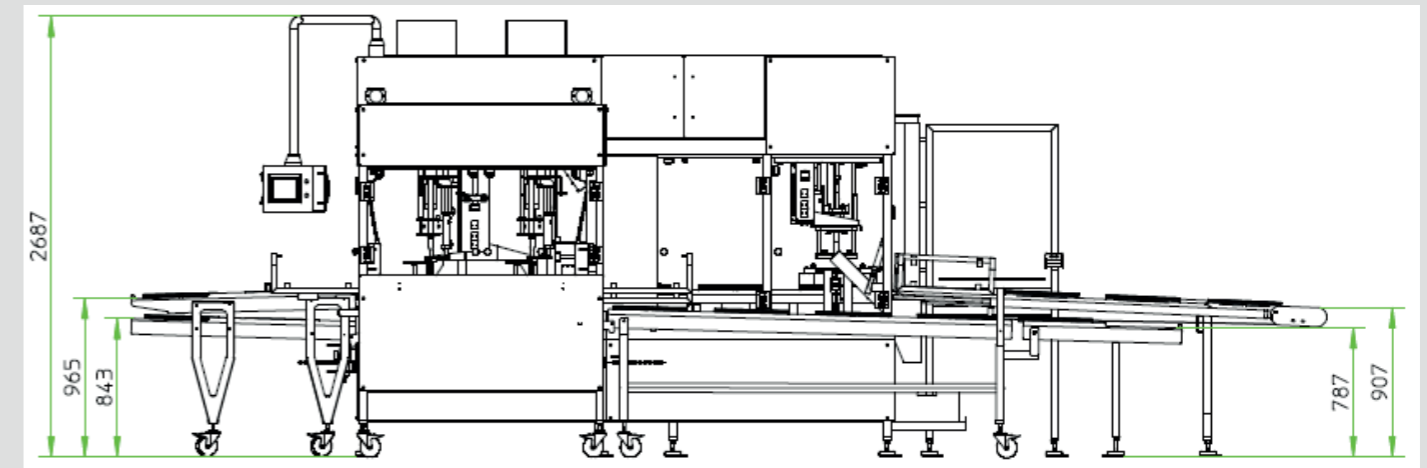



**iXAPACK GLOBAL**

Parc Économique de la Commanderie

Le Temple | BP3

79700 MAULÉON | France

+33 (0)5 49 82 05 80

[info@ixapack.com](mailto:info@ixapack.com)

[www.ixapack.com](http://www.ixapack.com)